



# Series 33A

Sizes 1" - 2" - 3" - 4" - 6"

## High Performance Combination Air Release & Vacuum Breaker Valve



Threaded



Flanged



NSF/ANSI 61 & 372

- Standard Maximum Operating Pressure 300 psi
- Standard Epoxy Coated Ductile Iron Body
- Automatically Eliminates Entrapped Air Pockets and Provides Vacuum Protection
- Easily Serviced
- Tested to Seal at 2 psi
- Meets AWWA C512 Requirements

Designed to protect pipelines and vertical turbine pump applications from air lock and vacuum collapse, the Model 33 A High Performance Combination Air Release and Vacuum Breaker Valve eliminates air and prevents vacuum formations in pipelines. A large venting orifice and large float clearances freely exhaust or admits air during pipeline filling or draining.

During normal pipeline operation, air accumulation and buoyancy cause the float ball to lower or lift. As the water level lowers inside the valve, small amounts of accumulated air are released through the small orifice. Once air is released, the float poppet system closes drip tight.

Valve servicing is simple because the entire float poppet system can be replaced without removal of the valve body from the pipeline.

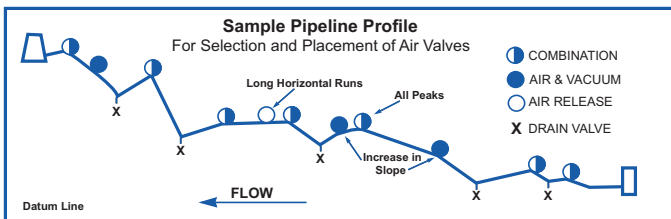

### Installation

Series 33A Combination Air Release and Vacuum Breaker Valves are typically installed at high points in pipelines for air release, or at anticipated pipeline vacuum occurrence locations. Install Series 33A at regular intervals (approximately 1/2 mile) along uniform grade line pipe. Mount the unit in the vertical position on top of the pipeline, and include an isolation/shutoff valve.

Series 33A is often installed upstream of check valves in pump discharges to vent air during start-up and to allow air reentry when the pump stops.

### Operation

#### Air Release Mode—Valve is normally open.

When line is filled or pump started, air is exhausted through the normally open 33A valve. As liquid fills the valve, float ball rises to form a drip-tight closure and remaining air is exhausted through small orifice.

**Vacuum Prevent Mode** When line pressure drops below positive pressure and the liquid level lowers, the float drops, unseating the valve and allowing air into the line, thus preventing a vacuum.

**Note:** Available for Sea Water Service See Material Specifications

### Typical Applications

- Transmission Pipeline High Points
- Water Treatment Plant Piping High Points
- Vertical Turbine Pump Discharge

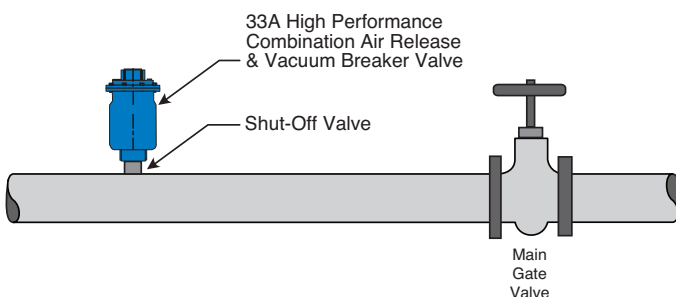

## Dimensions (In Inches)

## MODEL 33A Sizes - 1" - 2" - 3" - 4" - 6"

Valve Size	33A Pressure Class 300 Lb Threaded X Threaded				33A Pressure Class 150 Lb Threaded X Flanged				33A Pressure Class 150 Lb Flanged X Flanged
	1"	2"	3"	4"	2"	3"	4"	6"	6"
A	9.10	12.44	12.75	12.75	13.88	15.56	15.75	16.38	19.14
B	6.25	7.50	9.00	9.00	7.50	9.25	9.25	11.00	11.00
C	—	—	—	—	.62	.75	.94	1.00	1.06
Inlet (ANSI)	1" NPT	2" NPT	3" NPT	4" NPT	2"	3"	4"	6"	6"
Outlet (NPT)	1" NPT	2" NPT	3" NPT	4" NPT	2" NPT	3" NPT	4" NPT	6" NPT	6"
Number of Holes	—	—	—	—	4	4	8	8	8"
Diameter of Bolts	—	—	—	—	.63	.63	.75	.75	.75
Shipping Wt. (Lb.)	25	29	38	40	39	48	50	70	75

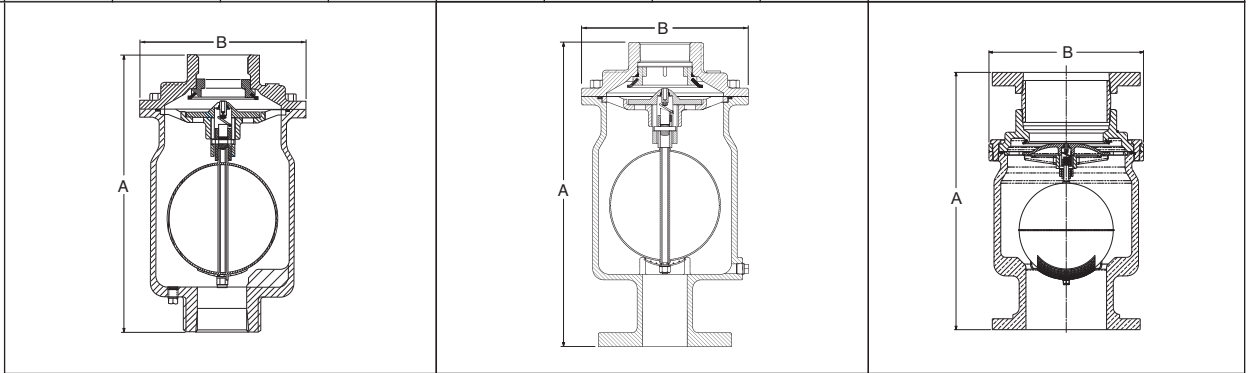

## Pressure Ratings

Size	Orifice Dia.	Std Max. Pressure	Available Materials of Construction
1"	.076"	300 psi	<ul style="list-style-type: none"> <li>Epoxy Coated Ductile Iron ASTM A536 65-45-12</li> <li>Epoxy Coated Cast Steel ASTM A 216WCB</li> <li>ASTM B61 Naval Bronze</li> <li>ASTM B 148 NI Aluminum Bronze</li> <li>316 Stainless Steel</li> <li>Duplex Stainless Steel</li> <li>Super Duplex Stainless Steel</li> <li>Bronze</li> </ul>
2"	.076"	300 psi	
3" & 4"	.076"	300 psi	
6"	.076"	300 psi	
3" & 4"	Optional upon request .125"	300 psi	

**Note:** Higher Pressures Available upon Request for sizes 2", 3", & 4"

## When Ordering, Specify:

- Catalog # 33A
- Valve Size
- Pressure Rating.
- Materials

## Specifications

### Standard Internals

**Float:** Stainless Steel 304SS Standard, Optional T316 or Monel

**Seals:** Nitrile Rubber or Optional Viton®

**Remainder of Internal Components:** Stainless Steel and Delrin

### Temperature Range

Water to 180° F

### Optional:

- Hood / Screen Assembly
- Throttling Device
- Goose Neck available 1" - 4"
- Arrestor Check 4" and 6"

SEE  
MODEL  
33AWS

## Valve Sizing Selection

### Large Orifice Vacuum Capacity

Determine anticipated water flow and allowable pressure differential for the pipeline application. Select valve from chart to exhaust or admit air at the same rate as water filling or draining (in CFS). For larger flows, two or more Model 33A's may be installed in parallel

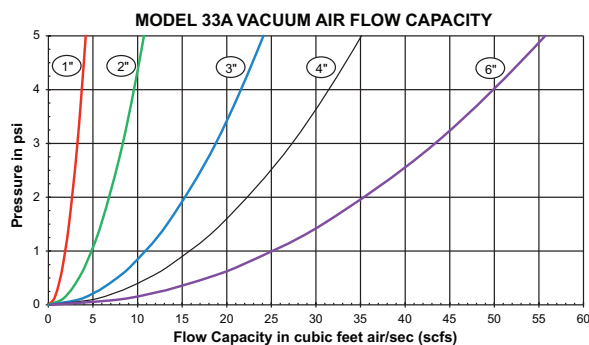

### Small Orifice Capacity - Air Release

During pressurized pipeline operation, small pockets of entrapped air will be released through the float actuated 0.076 or optional 0.125 inch orifice. Use chart to determine discharge capacity.

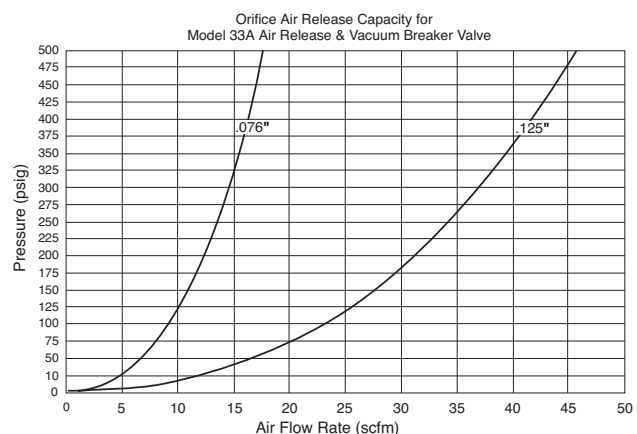

Shanghai Subo Automation Technology CO.,LTD  
Office:Room A503, No.1111 Xinzhen Street, Shanghai, China  
Office Hours: Monday - Friday 8:00 - 17:30  
.Mobile:+86 173 2103 4459

Web: www.shanghai-super.com  
Email:  
contact@shanghai-super.com  
business@shanghai-super.com  
inquiry@shanghai-super.com